



TUMBLE DRYERS | GREEN EVOLUTION



Tumble Dryers

FED - 65

FED - 80

Economic Line

SIMPLE BUT WITH THE SAME PERFORMANCE AND ROBUSTNESS



873FGD7E

- Auto-reverse Drum: the drying process is more efficient; offers better uniformity, avoiding the tangling of big pieces.
- Frequency inverter: controls rotating speed and reverse drum action.
- Drum motion by pulley and belts with the drum supported by wheels.
- **OPL ↔ Vended**
- Fagor dryers can be easily converted from OPL to Self-service and vice-versa.
- Cool Down: Anti-wrinkle at the end of cycle.
- Filter drawer with wide surface and improved airflow made of stainless steel.
- Outer casing in White painted galvanized steel.
- Radial airflow circuit.
- Ergonomic big loading door with a 180° opening.
- **M Control**: easy and intuitive electronic control with time and temperature selection.
- "Coin ready" M control is ready for the vended laundry. Compatible with almost all payment options.

OPTIONS:

- Optional screen to view time, temperature and program (up to 3 programs). The technical menu can also be accessed without having to use the console.



Add the optional external console or the easy display for more control of the process:

- Up 10 programs.
- Drum speed.
- Statistics.
- Technical menu.



TECHNICAL DATA	UNIT.	FED- 65	FED- 80		
CAPACITY					
Capacity 1/18	lb	70	80		
Capacity 1/20	lb	60	75		
Hourly Output*	lb/h	130.7	140.8		
Evaporation capacity*	l/h	30.9	32.1		
DRUM					
Ø Drum	in	37.25	37.25		
Ø Door	in	31.50	31.50		
Door center height	in	41	41		
Door Bottom Height	in	64.50	64.50		
Drum Depth	in	30.75	36.85		
Drum volume	cu ft	19.4	23		
POWER					
Drum motor power	hp	0.75	0.75		
Fan motor power	hp	0.75	0.75		
Electric heating power	kW	Not Available	Not Available		
Total electric power (elec.model)	kW	Not Available	Not Available		
Gas heating power	btu/h	140,000	140,000		
Total electric power (gas model)	kW	1.15	1.15		
Steam heating power	kW	50.1	50.1		
Steam heating power (gas model)	kW	1.15	1.15		
CONNECTIONS		ELECTRICAL	STEAM / GAS	ELECTRICAL	STEAM / GAS
120 V / 60 Hz / 1	FLA	-	30 A	-	30 A
208-240 V / 50-60 Hz / 1	FLA	Not Available	-	Not Available	-
208-240 V / 50-60 Hz / 3	FLA	Not Available	-	Not Available	-
Ø Gas inlet	BSP		1/2"		1/2"
Ø Steam inlet	BSP		1"		1"
Ø Condensed (Steam models)	BSP		1"		1"
DIMENSIONS / PACKING DIMENSIONS					
Net Width / Gross Width	in	38.75 / 42		38.75 / 42	
Net Depth / Gross Depth	in	41.50 / 45.50		47.60 / 51.60	
Net Height / Gross Height	in	76.60 / 82		76.60 / 82	
Height without heating battery	in	-		-	
Net weight / Gross weight	lb	507 / 573		573 / 628	
OTHERS					
Max airflow	CFM	706		706	
Ø Duct Size	in	8		8	
Sound level	dB	65		65	

* It may vary depending on the type of heating, filter cleanliness or extraction type.

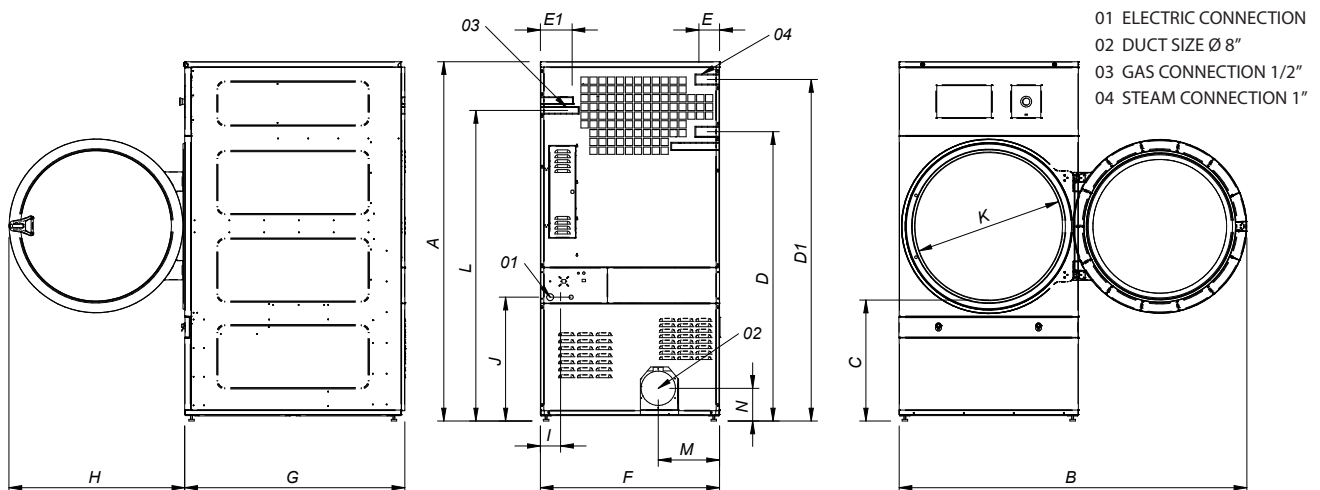

DIMENSIONS (in)	A	B	C	D	D1	E	E1	F	G	H	I	J	K	L	M	N
FED-65	76.60	75	25	62.60	74	4.50	6.85	38.75	41.50	37.75	4.30	26.75	31.60	67.25	13.35	7
FED-80	76.60	75	25	62.60	74	4.50	6.85	38.75	47.60	37.75	4.30	26.75	31.60	67.25	13.35	7

